

BS412



BS412

REL

PI R



USB



PIR



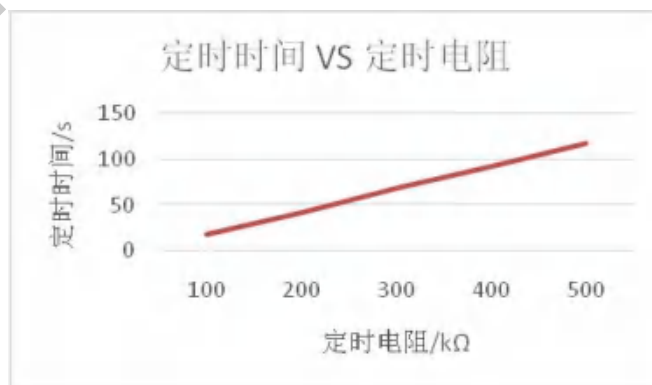
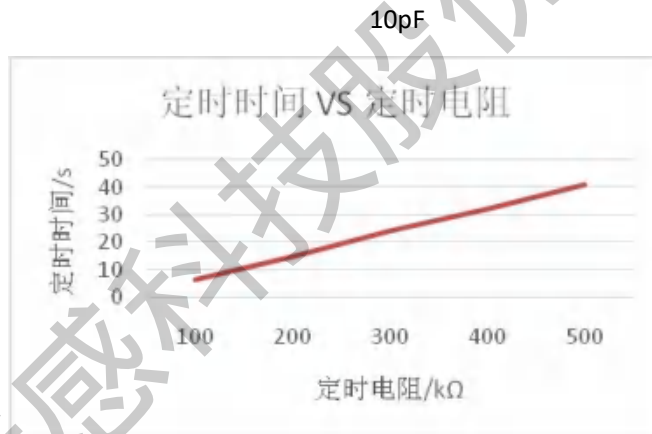
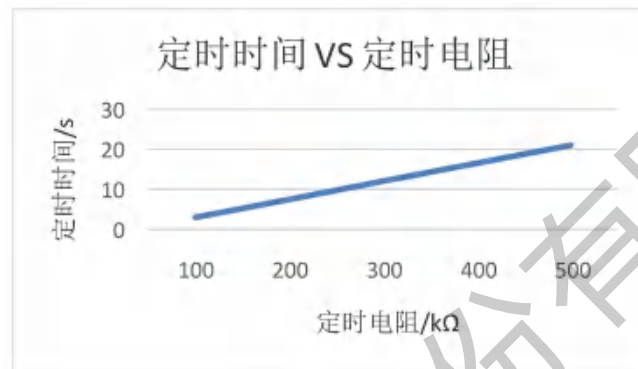
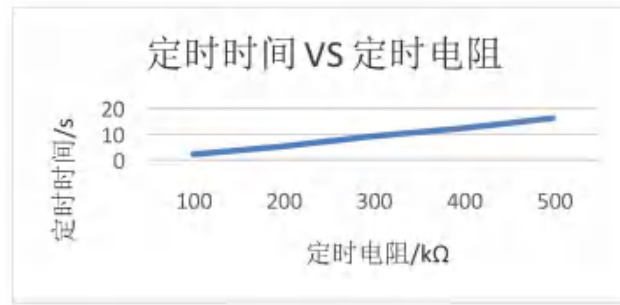

	S ( )	TIME		( 1%)	
				RH	RL
1	2	0~1/32VDD	1/64VDD	/1M	0R
2	5	1/32VDD~2/32VDD	3/64VDD	1M	51K
3	10	2/32VDD~3/32VDD	5/64VDD	1M	82K
4	15	3/32VDD~4/32VDD	7/64VDD	1M	120K
5	20	4/32VDD~5/32VDD	9/64VDD	1M	160K
6	30	5/32VDD~6/32VDD	11/64VDD	1M	200K
7	45	6/32VDD~7/32VDD	13/64VDD	1M	240K
8	60	7/32VDD~8/32VDD	15/64VDD	1M	300K
9	90	8/32VDD~9/32VDD	17/64VDD	1M	360K
10	120	9/32VDD~10/32VDD	19/64VDD	1M	430K
11	180	10/32VDD~11/32VDD	21/64VDD	1M	470K
12	300	11/32VDD~12/32VDD	23/64VDD	1M	560K
13	600	12/32VDD~13/32VDD	25/64VDD	1M	620K
14	900	13/32VDD~14/32VDD	27/64VDD	1M	750K
15	1800	14/32VDD~16/32VDD	29/64VDD	1M	820K
16	3600	15/32VDD~16/32VDD	31/64VDD	1M	910K

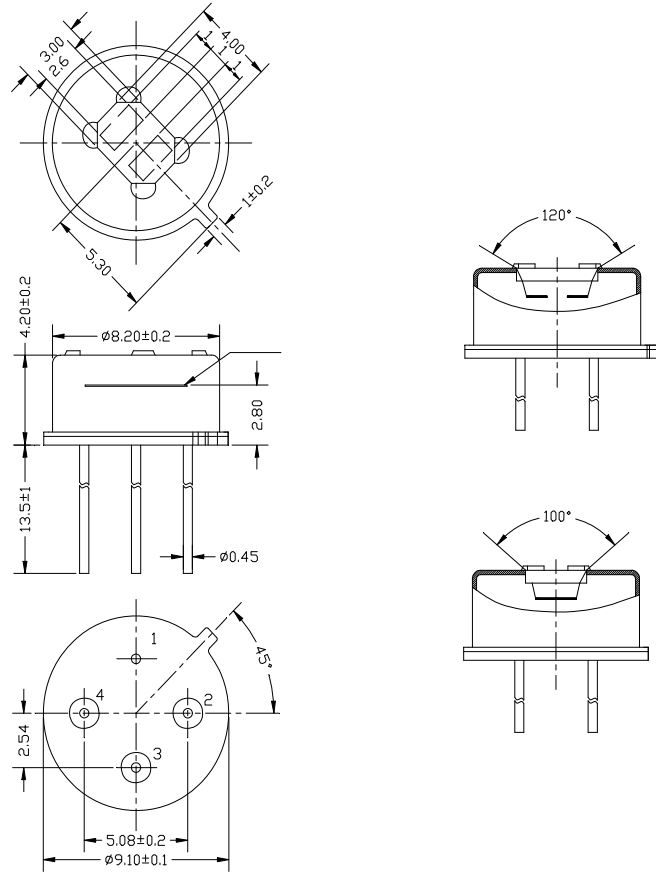

(Unit mm)

PIR



1	35	95	RH	500H
2	-40	500H		
3	80	500H		
4	-40	1H/	1H/40	1H/10
5	260	5	10S	3MM
			3	2H
	0.1MPa	1Min		



森霸传感科技股份有限公司  
SENBA SENSING TECHNOLOGY CO., LTD.

